

Dynamic Modeling of MicroGrids

G. N. Kariniotakis et al

Abstract— The interconnection of small, modular generation and storage technologies at the MV and LV distribution level have the potential to significantly impact power system performance. In this paper models of the main micro-generation sources are described. In particular, the models of Microturbines, Fuel Cells, Photovoltaic Systems and Wind Turbines, are described. In addition basic models of their power electronic interfaces are given. The above models have been integrated in a simulation platform able to represent the steady state and dynamic behavior of three phase networks. The simulation tool, which is developed in the framework of the EU funded MICROGRIDS project, is used to define and evaluate operational and control strategies for the microgrid paradigm.

Index Terms— Microgrids, Wind Turbines, Fuel Cells, Photovoltaic Systems, Micro-turbines, Transient Stability.

I. EXTENDED SUMMARY

Small, modular generation technologies interconnected to Slow-voltage (LV) distribution systems have the potential to form a new type of power system, the MicroGrid [1, 2]. MicroGrids can be connected to the main power network or be operated autonomously, if they are operated from the power grid, in a similar manner to the power systems of physical islands. The micro-generators are small units of less than 100 kW, most of them with power electronic interface, using either Renewable Energy Sources or fossil fuel in high efficiency local co-generation mode. Both of these technologies are critical to reducing GHG emissions and dependence on imported fossil fuel, where the MicroGrid concept will allow their most effective implementation.

MicroGrids may use single-phase circuits and be loaded with single-phase loads. These factors generate unbalanced conditions that can be accentuated with the interaction of dynamic loads such as induction motors. To model these effects, analysis tools must model the system with its three phases, the neutral conductors, the ground conductors and the connections to ground. Such tools should include steady state and dynamic models for the various forms of micro-sources and their interfaces.

This paper presents the microsources models as well as the simulation platform developed in the frame of the

MICROGRIDS project [1]. The platform is able to simulate the steady state and dynamic operation of LV three-phase networks that include micro generation. This involves the development of adequate models in the time range of ms of the micro sources, machines (induction and synchronous machines) and inverters [3]. Normally these devices are directly coupled to the grid and thus have a direct impact on the grid voltage and frequency. In this paper the following models are described:

- Induction Generators
- Micro-turbines
- Photovoltaic Systems
- Fuel Cells
- Wind Turbines
- Grid-side inverter generic model.

The analytical simulation tool is capable of representing the dynamic behavior of micro-grids during grid-connected and autonomous operation, both in balanced and unbalanced conditions. The whole tool is built in Matlab around a sophisticated network solver. The paper provides the basic theory, on which the micro-grid network solver is based, as well as selected applications to demonstrate its appropriateness and capability of efficiently simulating the main operating modes of a micro-grid.

The simulation model is described, for which the frequency domain representation (phasor approach) has been adopted to increase the simulation efficiency. Natural phase quantities (a-b-c) are used, with proper treatment of neutral conductors. Microsources and dynamic loads are interfaced to the network solver via their «stator EMF-behind-reactance» equivalent. Network, load and source unbalance can be easily handled by the network solver.

The simulation code has been extensively tested in various network conditions and disturbances and its adequacy is verified by the study cases presented in the paper.

Several representative study cases are presented in the paper. All cases are based on the LV study case network shown in Fig. 1 as the main testing network. This is a model of a microgrid network that was developed in [1] in order to be used as reference network for benchmarking purposes. The study cases examined cover broadly the following conditions:

- Operation of the network with multiple battery inverters as grid-forming units.
- Operation with the battery inverters and PVs connected at various nodes.
- Operation with the battery inverters, PVs and WTs within the same network.

This work was supported in part by the European Commission under the 5th Framework Program, Contract No ENK5-CT-2002-00610.

G. N. Kariniotakis is with Center for Energy and Processes of Ecole des Mines de Paris, B.P. No 207, Sophia-Antipolis Cedex, France (e-mail: georges.kariniotakis@cep.cma.fr).

Disturbances considered include:

- Isolation from the main grid.
- Step changes of the load in the micro-grid.
- Variations of the production of dispersed PVs and WTs
- Loss of grid forming units (battery inverters).

In all cases, the simulation results are very reasonable and expected, confirming the suitability of the code for the dynamic analysis of microgrids. Finally the paper presents a detailed sensitivity analysis on the results that aim to verify the feasibility of the Microgrid concept in general.

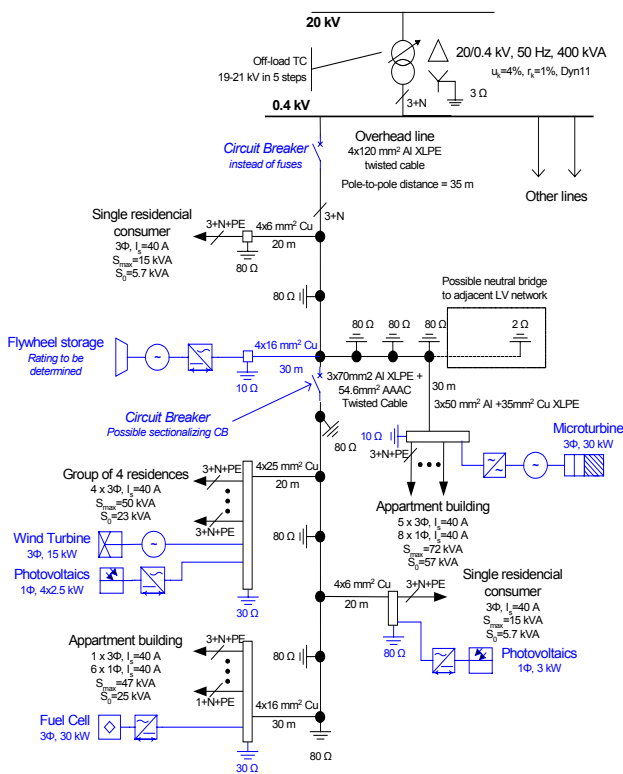

Fig. 1. Example microgrid. LV feeder integrating microsources.

The following Figures demonstrate some results obtained from the simulation platform. The simulated scenario consists of a microgrid in which battery are present together with two PV units and one wind turbine. The disturbance that is applied is isolation of the microgrid from the main grid while at the same time the wind production is fluctuating.

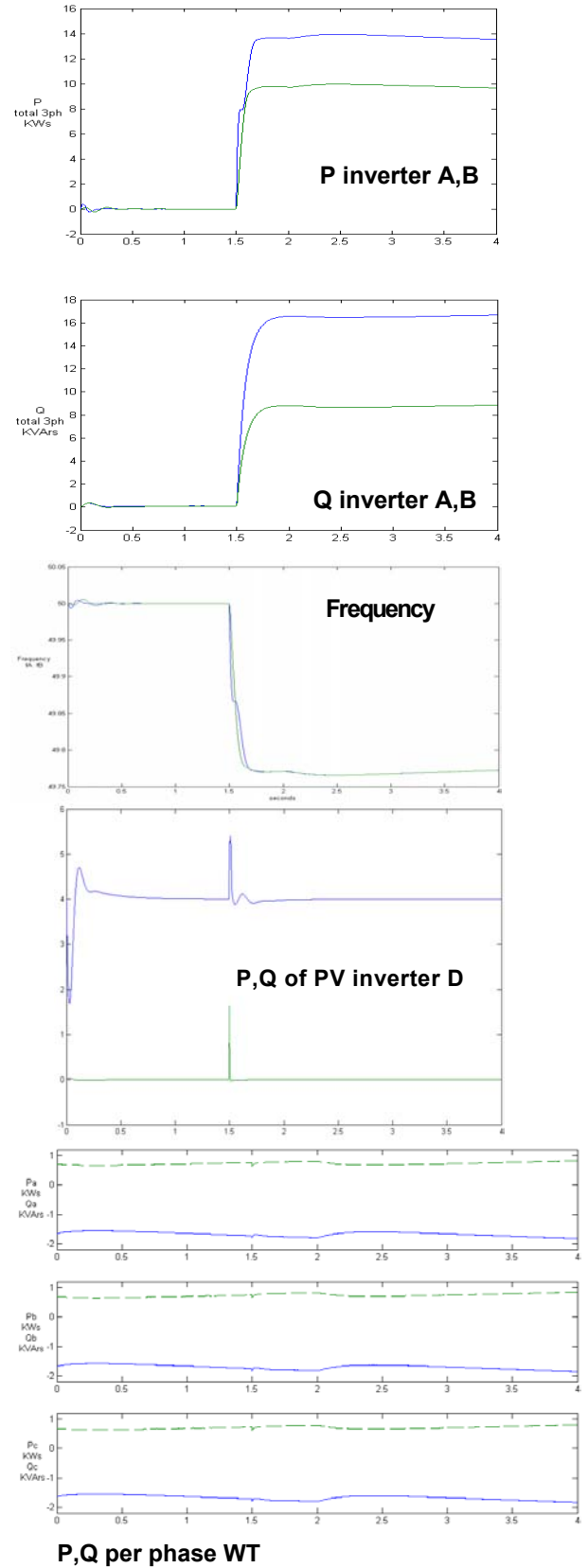

Fig. 2. Examples of results obtained by the developed simulation platform. The figures depict the response of several quantities in the microgrid following is disconnection from the main grid and under fluctuating wind generation.

II. REFERENCES

- [1] "MICROGRIDS – Large Scale Integration of Micro-Generation to Low Voltage Grids", EU Contract ENK5-CT-2002-00610, <http://microgrids.power.ece.ntua.gr>
- [2] "The CERTS Microgrid Concept", White paper on Integration of Distributed Energy Resources, R. Lasseter et al, April 2002
- [3] Technical Brochure CIGRE Task Force 38.01.10, "Modeling New Forms of Generation and Storage", Nov. 2000.
- [4] F. D. Kanellos, N.D. Hatziargyriou, "The Effect of Variable Speed Wind Turbines on the Operation of Weak Distribution Networks", *IEEE Trans. on Energy Conversion*, vol: 17, issue: 4, pages: 543 -548, December 2002.
- [5] J.H. Watts, "Microturbines: a new class of gas turbine engines", *Gas Turbine News in Brief* 39 (1), 5-11, 1999.
- [6] M. Nagpal, A. Moshref, G.K. Morison, et al., "Experience with testing and modeling of gas turbines", *Proc. of the IEEE/PES 2001 Winter Meeting*, pp. 652-656, Jan./Feb. 2001, Columbus, Ohio, USA.
- [7] [7] Y. Zhu, K. Tomsovic, "Development of models for analyzing load-following performance of microturbines and fuel cells", *Electric Power Systems Research* 62, 1-11, 2002.
- [8] J. C. H. Phang, D. S. H. Chan, J. R. Phillips, "Accurate Analytical Method for the Extraction of Solar Cell Model Parameters", *Electronics Letters*, 10th May 1984 Vol. 20 No. 10, pp. 406-408.
- [9] D. L. King, "Photovoltaic Module and Array Performance Characterization Methods for All System Operating Conditions," NREL/SNL Program Review, AIP Press, 1996, pp.347-368.
- [10] Schauder, C., Mehta, H., "Vector Analysis and Control of Advanced Static VAR compensators", *IEE PROCEEDINGS-C*, Vol. 140, No.4, July 1993.